

Sheet: /PSU/		
File: PSU.kicad_sch		
<b>Title:</b>		
Size: A3	Date:	Rev:
KiCad E.D.A. kicad 7.0.6		Id: 2/11

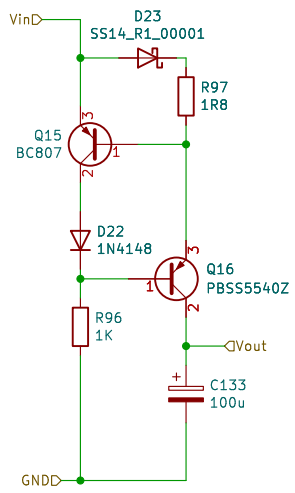

Sheet: /periphCurrLimiter/  
 File: periphCurrLimiter.kicad\_sch

**Title:**

Size: A4

Date:

Rev:

KiCad E.D.A. kicad 7.0.6

Id: 3/11

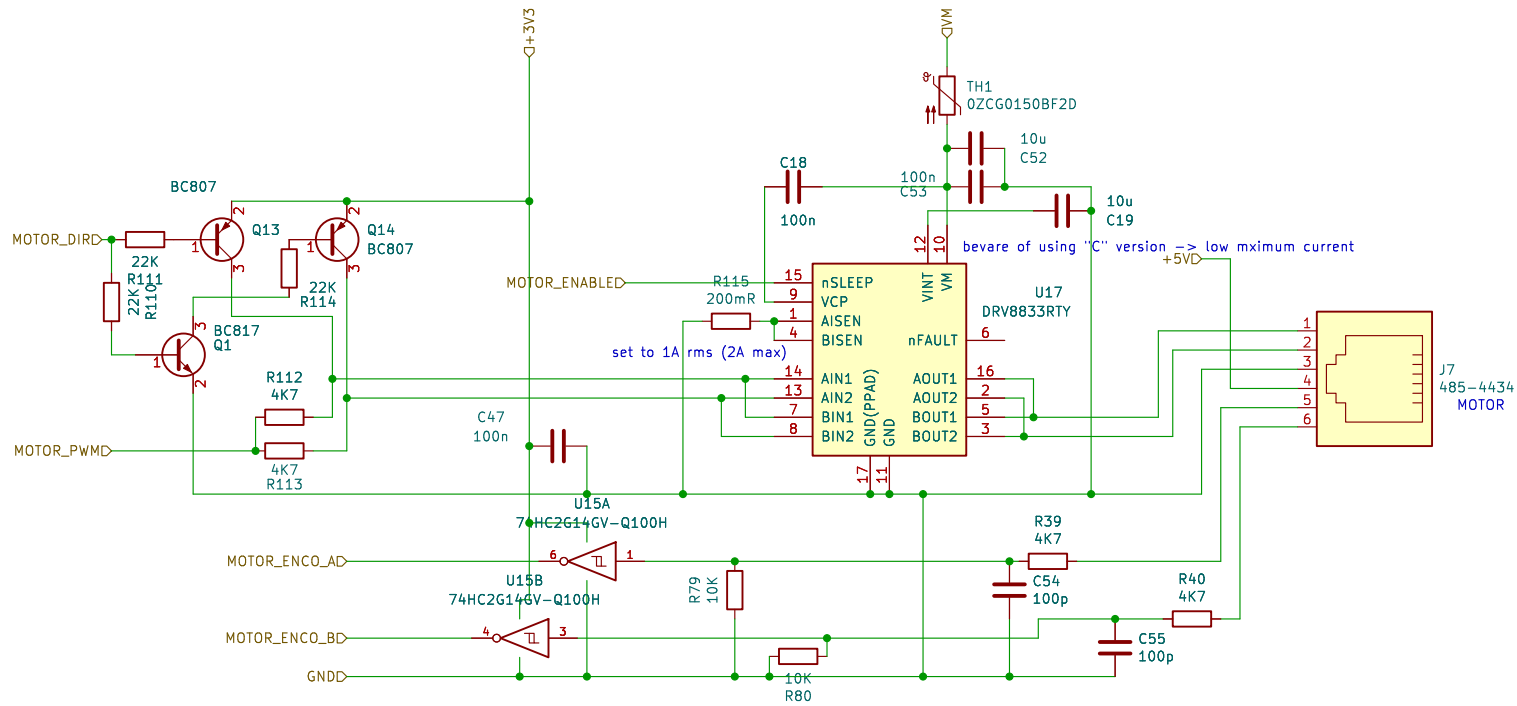

Sheet: /motor5/  
 File: motor4.kicad\_sch

**Title:**

Size: A4  
 KiCad E.D.A. kicad 7.0.6

Date:  
 Rev:  
 Id: 4/11

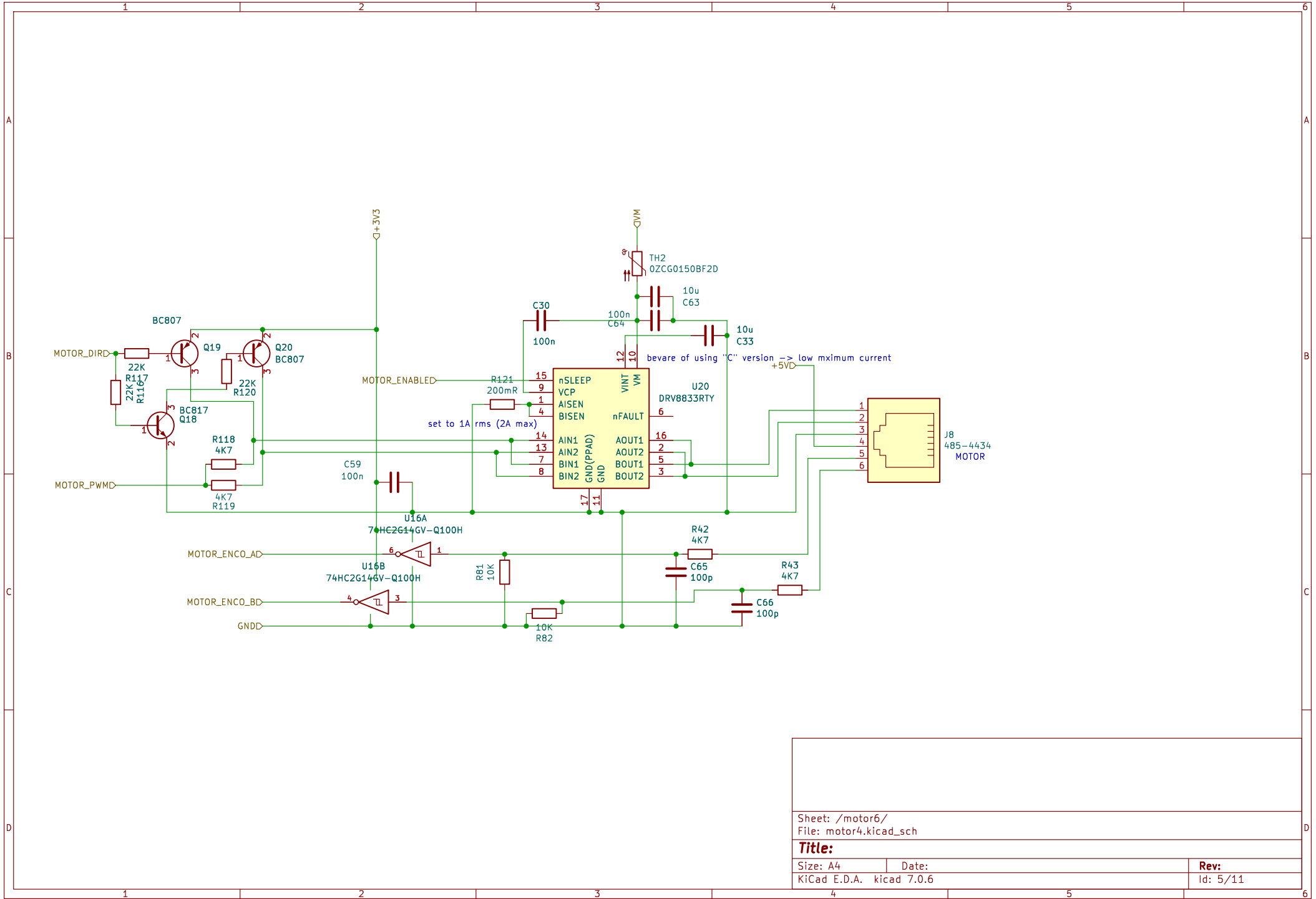

Sheet: /motor6/	
File: motor4.kicad_sch	
<b>Title:</b>	
Size: A4	Date:
KiCad E.D.A. kicad 7.0.6	Rev: Id: 5/11

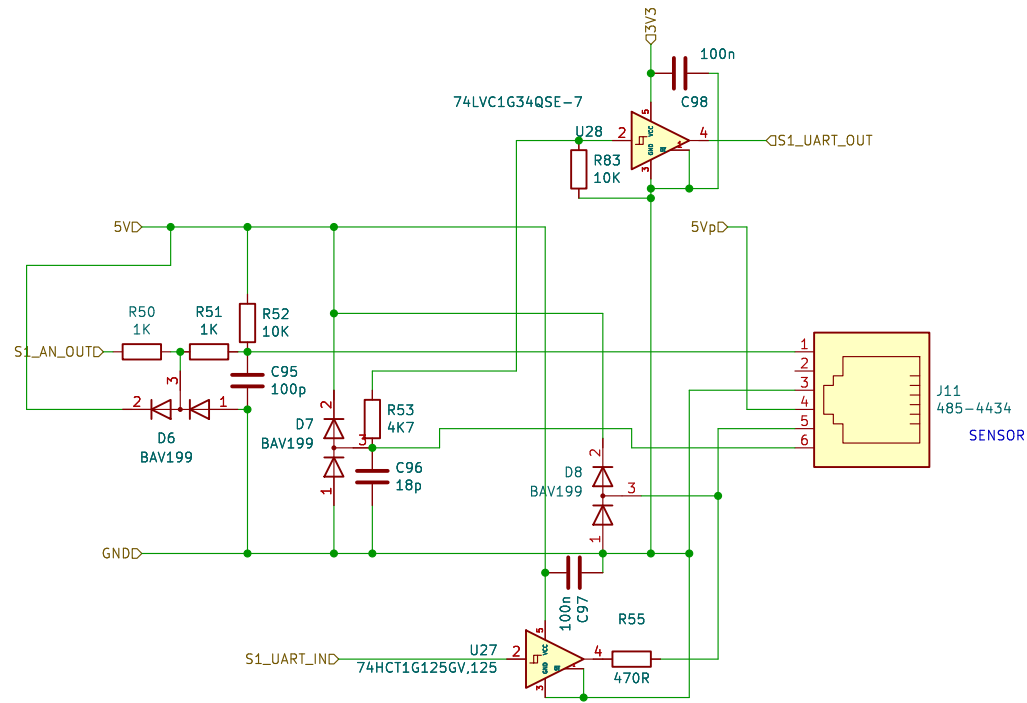

Sheet: /sensor1/  
 File: sensor1.kicad\_sch

**Title:**

Size: A4  
 KiCad E.D.A. kicad 7.0.6

Date:  
 Rev:  
 Id: 6/11

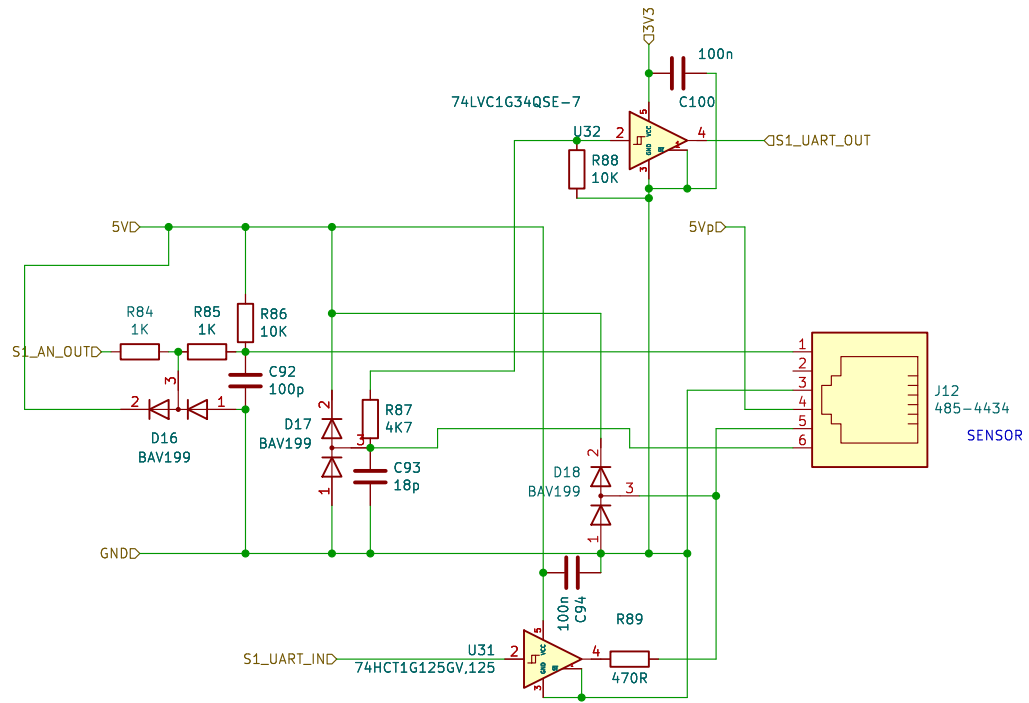

Sheet: /sensor2/  
 File: sensor1.kicad\_sch

**Title:**

Size: A4  
 KiCad E.D.A. kicad 7.0.6

Date:

**Rev:**  
 Id: 7/11

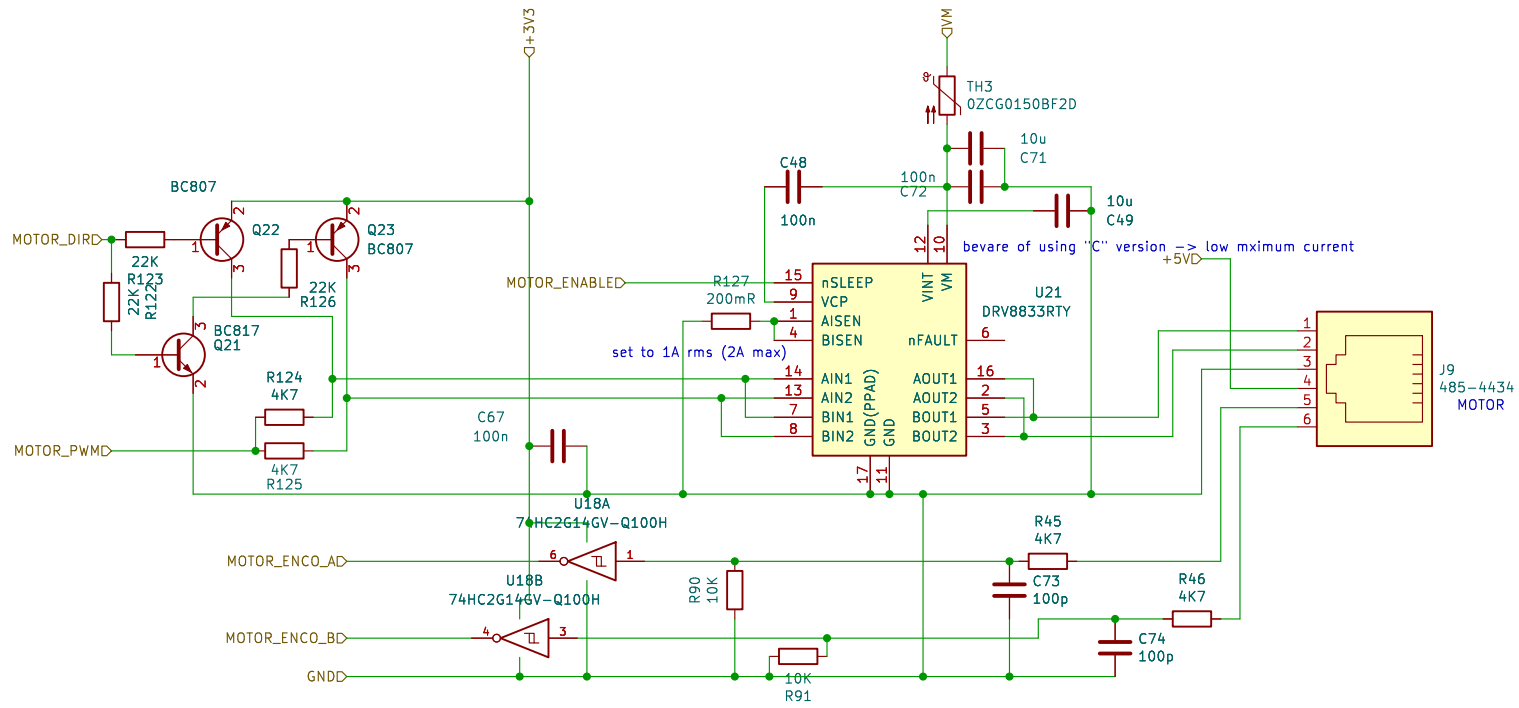

Sheet: /motor7/  
 File: motor4.kicad\_sch

**Title:**

Size: A4  
 KiCad E.D.A. kicad 7.0.6

Date:  
 Rev:  
 Id: 8/11



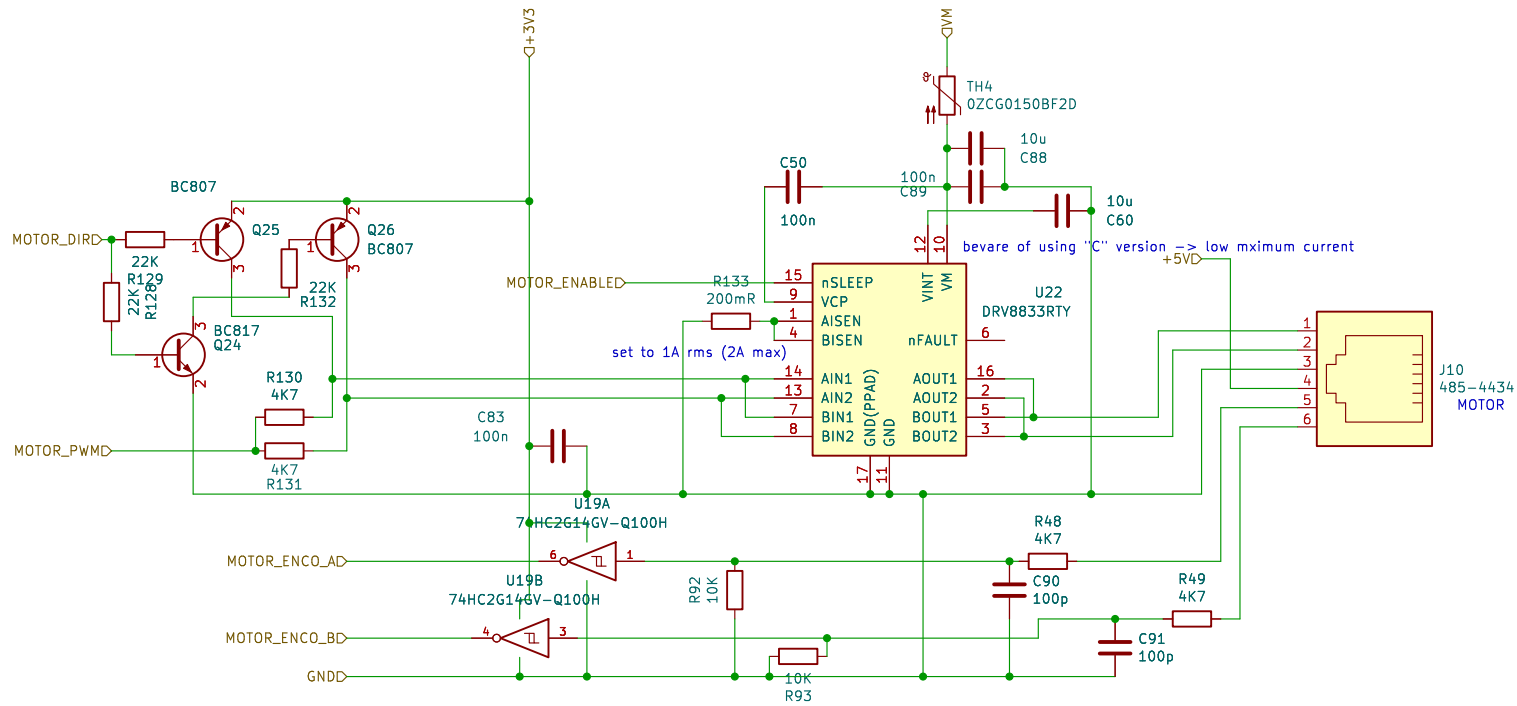

Sheet: /motor4/  
 File: motor4.kicad\_sch

**Title:**

Size: A4 Date:  
 KiCad E.D.A. kicad 7.0.6

**Rev:**  
 Id: 9/11

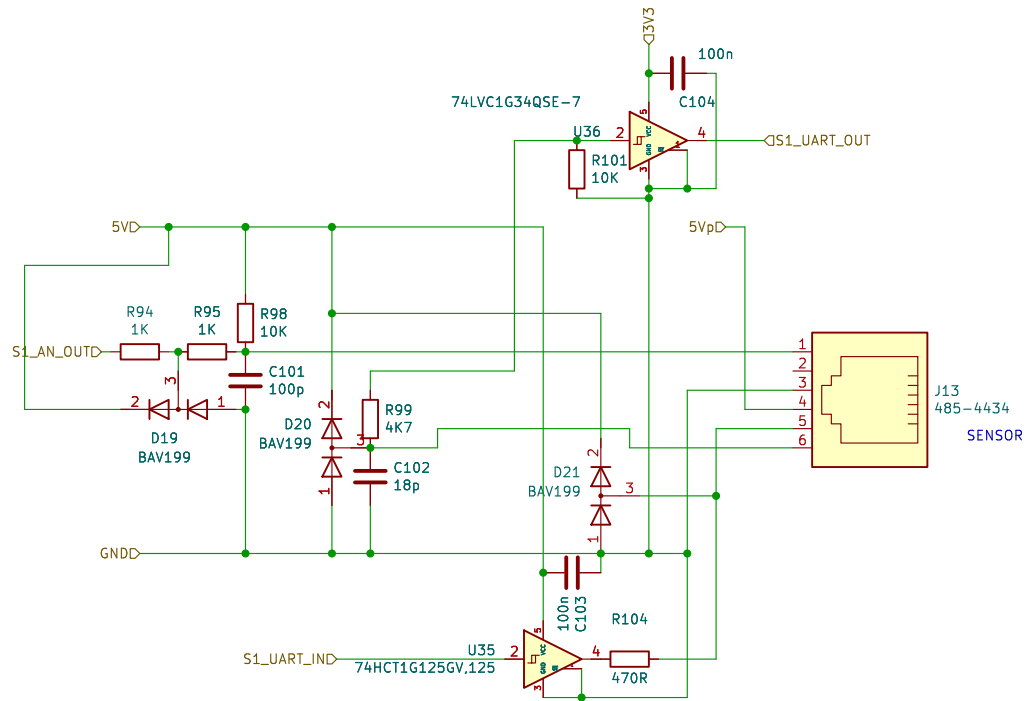

Sheet: /sensor3/  
 File: sensor1.kicad\_sch

**Title:**

Size: A4  
 KiCad E.D.A. kicad 7.0.6

Date:

Rev:  
 Id: 10/11

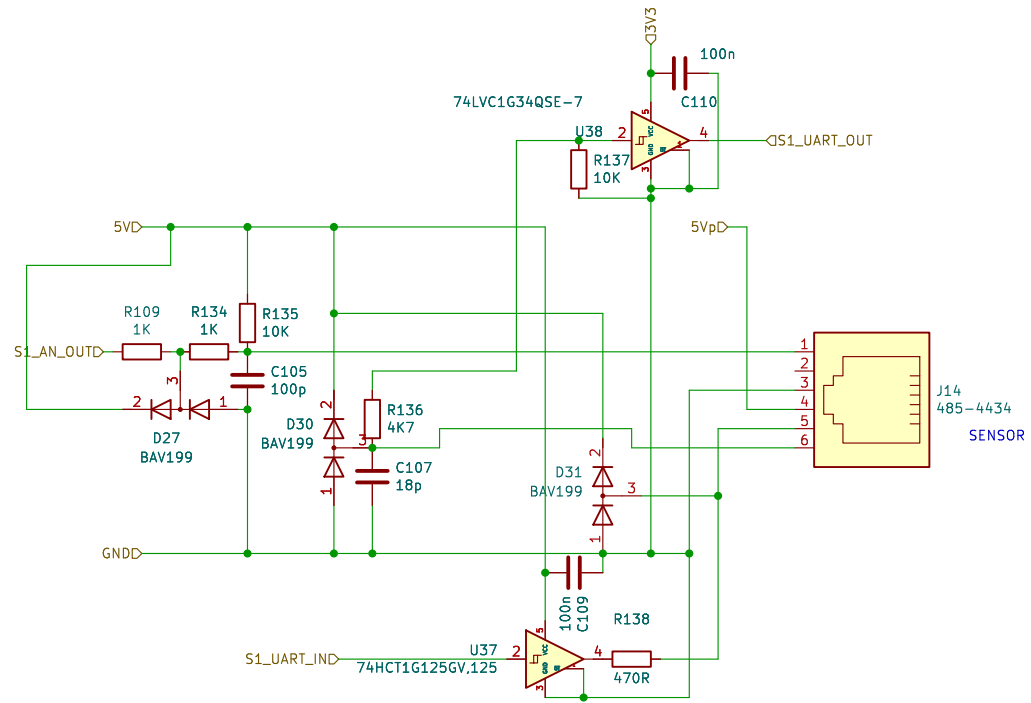

Sheet: /sensor4/  
 File: sensor1.kicad\_sch

**Title:**

Size: A4  
 KiCad E.D.A. kicad 7.0.6

Date:  
 Rev:  
 Id: 11/11